

Instruction Guide  
with Warranty

**RugDoctor**<sup>®</sup>  
The Carpet Care Experts



# Hot-Water Extraction Carpet Cleaning Machine

Applies to all Mighty Pro<sup>®</sup> and Wide Track machines



Includes  
Hand Tool Attachment

### Retain for your records.

To save time if calling  
Customer Service for  
information about your  
Rug Doctor Machine,  
it is recommended that  
you record your machine  
information here:

SERIAL NUMBER:

(Found on the top silver plate  
of your machine under the barcode.)

This Product is ETL Listed  
and conforms to UL Standard 1017  
Certified to CAN/CSA C22.2 No. 243



Patents: 5,473,792 & 5,513,415 &  
6,216,313 & DES. 364,947

**RugDoctor**<sup>®</sup>

Rug Doctor, Inc.  
4701 Old Shepard Place  
Plano, TX 75093-9065  
Consumer Support Hotline:  
1-800 RUG DOCTOR  
(1-800-784-3628)  
www.rugdoctor.com



## Redefining Carpet Cleaning

Rug Doctor was founded by a professional carpet cleaner back in 1972 with the first machines having been designed and built for professional use. It was soon realized that the machine was so easy to use, anyone, not only professionals, could deep clean carpets. A brand was born and soon after, Rug Doctor launched the first rental program that made professional-grade carpet cleaning machines available to the public.

More than 35 years later, Rug Doctor has grown to become a household name and continues as the leader in carpet care rental systems with powerful machines and innovative products.

With your new Rug Doctor, you now you have this same professional power in your home. We believe you'll find it to be a product that not only lives up to Rug Doctor's high standards of quality and performance, but yours as well. With the recommended care and maintenance, your Rug Doctor machine will provide years of reliable service.

Thank you for purchasing a Rug Doctor and welcome to the Rug Doctor family!



## Now that you own a Rug Doctor machine, discover all of the ways you can clean...

In addition to deep cleaning carpet, you can clean so much more using Rug Doctor attachments.



**Deep Clean Upholstery**

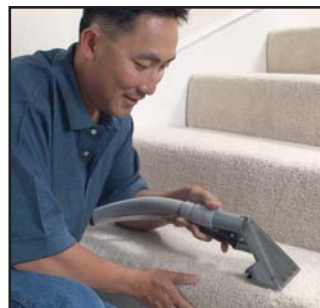

**Stairs, Cars, Boats, RVs**



**Tile, Linoleum, Concrete and more**

The optional Floor Doctor® attachment can be used to clean hard surface floors in your home. Lightweight and easy-to-use, this hard floor tool effectively cleans and dries floors in seconds. It is great for cleaning concrete, marble, granite, linoleum, vinyl, Formica®, Corian®, and ceramic tile in just one pass. To order the Floor Doctor for your Rug Doctor machine, call 1-800-Rug Doctor (1-800-784-3628) or visit [www.rugdoctor.com](http://www.rugdoctor.com).

# It's So Easy!

# Important Safety Instructions

When using an electrical appliance, basic precautions should always be followed, including the following:

## READ ALL INSTRUCTIONS BEFORE USING

### **WARNING**—To reduce the risk of fire, electric shock, or injury:

- Do not leave appliance when plugged in. Unplug from outlet when not in use and before servicing.
- To Reduce the Risk of Fire and Electric Shock due to internal component damage, use only Rug Doctor cleaning products intended for use with this appliance. See the Cleaning Product section of this manual.
- **WARNING**—To reduce the risk of electric shock - use indoors only.
- Do not allow to be used as a toy. Close attention is necessary when used by or near children.
- Use only as described in this manual. Use only manufacturer's recommended attachments.
- Do not use with damaged cord or plug. If appliance is not working as it should, has been dropped, damaged, left outdoors, or dropped into water, return it to a service center.
- Do not pull or carry by cord, use cord as a handle, close a door on cord, or pull cord around sharp edges or corners. Do not run appliance over cord. Keep cord away from heated surfaces.
- Do not unplug by pulling on cord. To unplug, grasp the plug, not the cord.
- Do not handle plug or appliance with wet hands.
- Do not put any object into openings. Do not use with any opening blocked; keep free of dust, lint, hair, and anything that may reduce air flow.
- Keep hair, loose clothing, fingers, and all parts of body away from openings and moving parts.
- Turn off all controls before unplugging.
- Use extra care when cleaning on stairs.
- Do not use to pick up flammable or combustible liquids such as gasoline or use in areas where they may be present.
- Do not use to pick up anything that is burning or smoking, such as cigarettes, matches, or hot ashes.
- Do not use without filters in place.
- Connect to a properly grounded outlet only. See "Grounding Instructions."
- Use only on surfaces moistened by cleaning process or small spills. Do not place machine in standing water or try to clear flooded areas.
- Do not clean over floor electrical outlets.
- Do not use without upper (white) tank in place.
- The use of an extension cord is not recommended.

## SAVE THESE INSTRUCTIONS

# Importantes Mesures de Sécurité

L'utilisation d'un appareil électrique demande certaines précautions:

## LIRE TOUTES LES INSTRUCTIONS AVANT DE FAIRE FONCTIONNER

### **AVERTISSEMENT**—Pour réduire les risques d'incendie, de choc électrique ou de blessure:

- Ne pas laisser l'appareil sans surveillance lorsqu'il est branché. Débrancher lorsque l'appareil n'est pas utilisé et avant l'entretien.
- Afin de réduire les risques d'incendie et de décharge électrique provoqués par des composants internes endommagés, utilisez uniquement les produits de nettoyage Rug Doctor conçus pour ce produit. Lire la section consacrée aux produits de nettoyage dans le présent manuel.
- **AVERTISSEMENT**—Pour réduire les risques de choc électrique, utiliser à l'intérieur seulement.
- Ne pas permettre aux enfants de jouer avec l'appareil. Une attention particulière est nécessaire lorsque l'appareil est utilisé par des enfants ou à proximité de ces derniers.
- N'utiliser que conformément à cette notice avec les accessoires recommandés par le fabricant.
- Ne pas utiliser si le cordon ou la fiche est endommagé. Retourner l'appareil à un atelier de réparation s'il ne fonctionne pas bien, s'il est tombé ou s'il a été endommagé, oublié à l'extérieur ou immergé.
- Ne pas tirer soulever ni traîner l'appareil par le cordon. Ne pas utiliser le cordon comme une poignée, le coincer dans l'embrasure d'une porte ou l'appuyer contre des arêtes vives ou des coins. Ne pas faire rouler l'appareil sur le cordon. Garder le cordon à l'écart des surfaces chaudes.
- Ne pas débrancher en tirant sur le cordon. Tirer plutôt la fiche.
- Ne pas toucher la fiche ni l'appareil lorsque vos mains sont humides.
- N'insérer aucun objet dans les ouvertures. Ne pas utiliser l'appareil lorsqu'une ouverture est bloquée. S'assurer que de la poussière, de la peluche, des cheveux ou d'autres matières ne réduisent pas le débit d'air.
- Maintenir les cheveux, les vêtements amples, les doigts et toutes les parties du corps à l'écart des ouvertures et des pièces mobiles.
- Mettre toutes les commandes à la position ARRÊT avant de débrancher l'appareil.
- User de prudence lors du nettoyage des escaliers.
- Ne pas aspirer des liquides inflammables ou combustibles, comme de l'essence, et ne pas faire fonctionner dans des endroits où peuvent se trouver de tels liquides.

- Ne pas aspirer de matières en combustion ou qui dégagent de la fumée, comme des cigarettes, des allumettes ou des cendres chaudes.
- Ne pas utiliser sans les filtres en place.
- Ne brancher qu'à une prise de courant avec mise à la terre. Voir les instructions visant la mise à la terre.
- N'utiliser que sur des surfaces mouillées par le procédé de nettoyage ou par des petits débordements. Ne pas placer la machine dans de l'eau stagnante ou pour nettoyer une zone inondée.
- Ne pas nettoyer au-dessous des prises électriques au sol.
- Ne pas utiliser sans le réservoir supérieur (blanc) en place.
- L'utilisation d'une rallonge n'est pas conseillée.

## CONSERVER CES INSTRUCTIONS

### Grounding Instructions

This appliance must be grounded. If it should malfunction or breakdown, grounding provides a path of least resistance for electric current to reduce the risk of electric shock. This appliance is equipped with a cord having an equipment-grounding conductor and grounding plug. The plug must be inserted into an appropriate outlet that is properly installed and grounded in accordance with all local codes and ordinances.

**WARNING**—Improper connection of equipment-grounding conductor can result in a risk of electric shock. Check with a qualified electrician or service person if you are in doubt as to whether the outlet is properly grounded. Do not modify the plug provided with the appliance—if it will not fit the outlet, have a proper outlet installed by a qualified electrician.

This appliance is for use on a nominal 120-volt circuit and has a grounded plug that looks like the plug illustrated in Figure A. Make sure that the appliance is connected to an outlet having the same configuration as the plug. No adapter should be used with this appliance.

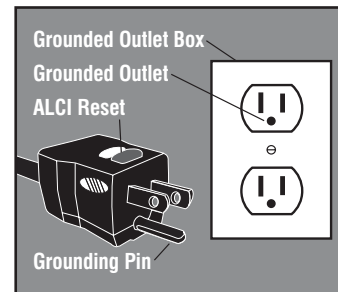

Figure A

### Instructions visant la mise à la terre

Cet appareil doit être mis à la terre. En cas de défaillance ou de panne, la mise à la terre fournit au courant un chemin de moindre résistance qui réduit le risque de choc électrique. Cet appareil est pourvu d'un cordon muni d'un conducteur de terre et d'une fiche avec broche de terre. La fiche doit être branchée dans une prise appropriée correctement installée et mise à la terre conformément aux règlements et ordonnances municipaux.

**AVERTISSEMENT**—Un conducteur de terre mal raccordé peut entraîner un risque de choc électrique. Consulter un électricien ou un technicien d'entretien qualifié si vous n'êtes pas certain que la prise est correctement mise à la terre. Ne pas modifier la fiche fournie avec l'appareil - si elle ne peut être insérée dans la prise, faire installer une prise adéquate par un électricien qualifié.

Cet appareil est destiné à un circuit de 120 V et est muni d'une fiche de mise à la terre semblable à celle illustrée à la figure A. S'assurer que l'appareil est branché à une prise de courant ayant la même configuration que la fiche. Aucun adaptateur ne devrait être utilisé avec cet appareil.

# Cleaning with Your Rug Doctor Machine and Products.

Read all instructions completely before you begin.

## Before You Begin

To assure proper results, test carpets and upholstery for colorfastness. Wet an inconspicuous area with a small amount of cleaner. After 1–2 minutes, blot with a white paper towel and check for color transfer. Follow these additional guidelines when cleaning with your Rug Doctor machine:

- Rug Doctor machines and Rug Doctor cleaning products are safe for most carpets. However, you risk damage to carpets and hard floor surfaces not intended for water extraction method cleaning. **Do not use the Rug Doctor machine or cleaning products on natural fiber oriental rugs (silk or wool), hand-loomed wool rugs, braided rugs, sisal or jute carpets; hardwood or laminate flooring.** Some stains require professional treatment. Use cool water when cleaning wool, wool blends or delicate fibers.
- Rug Doctor machines and Rug Doctor cleaning products are safe for many fabrics, even delicate fibers. However, you risk damage to fabrics not intended for water extraction method cleaning. **Do not use Rug Doctor machines or products to clean fabric with cleaning codes S or X, silk, Haitian cotton, velour, brushed corduroy, leather or non-colorfast fabrics, mattresses or mattress toppers made with memory foam, foam or goose down.** Some stains require professional treatment. Use cool water when cleaning wool, wool blends or delicate fibers.
- The machine was designed for use on carpet and upholstery applications as per instructions and recommendations in this manual. If you use the Rug Doctor machine to clean surfaces other than carpet and upholstery, such as hard surface floors, use only Rug Doctor recommended products. Rug Doctor Oxy-Steam Carpet Cleaner can be safely and effectively used for either carpeting or water-safe hard surface floor coverings.
- To Reduce the Risk of Fire and Electric Shock due to internal component damage, use only Rug Doctor cleaning products intended for use with this appliance.
- Afin de réduire les risques d'incendie et de décharge électrique provoqués par des composants internes endommagés, utilisez uniquement les produits de nettoyage Rug Doctor conçus pour ce produit.
- Avoid picking up hard or sharp objects with the carpet cleaning machine. They may damage the machine.
- Do not use the machine for dry vacuuming because this machine does not have a fine dust filter. Dry vacuuming damages the vacuum motor.
- Do not use the machine to vacuum large quantities of liquid, such as a flooded basement or large spill. This machine is not equipped with an automatic overflow shutoff.
- To avoid pump damage, do not continue to press the spray (pump) switch when the solution tank is empty.
- Do NOT put bleach, dye or products other than Rug Doctor cleaners in this machine. Use of inappropriate products may cause this machine to malfunction and may result in carpet or machine damage.
- Read instructions carefully. Rug Doctor, Inc. is not responsible for damage due to misuse of this machine.
- **Always use Anti-Foam with Upholstery Cleaner or when otherwise needed to prevent excess sudsing in the upper (white) tank.** Foam should never be ingested through the dome filter. Damage to the carpet and/or vacuum motor could result.
- To avoid damage, do not place the machine or hand tool on hardwood or laminate flooring or allow any solution or overspray to contact such flooring.

## Carpet Cleaning Tips for Best Results

Follow these guidelines when cleaning carpets with your Rug Doctor machine.

- **Treating difficult spots.** Rug Doctor machines are designed to deep clean and extract in one cleaning pass. Your best choice for cleaning difficult spots, stains or traffic areas is to use Rug Doctor's specialty products: Hi-Traffic Pre-Treatment, Spot & Stain Remover, Urine Eliminator, or Odor Remover.
- **Avoid over-wetting your carpet.** Rug Doctor machines are designed to deep clean and extract in one cleaning pass. Don't go over a heavily-soiled spot more than 2 times. Berber, Multi-level or Looped carpets retain more liquid. For these types of carpets, do NOT repeat cleaning passes. If additional cleaning is desired, allow carpets to dry before attempting to reclean heavily-soiled areas. Because they retain more liquid, Berber carpets that are overwet can experience "wick up" of soils or spills very deeply embedded in the carpet or backing. If you experience this problem, allow area to dry completely then clean again using single, quick passes (2 feet per second) with the Rug Doctor machine.
- **Overlap passes slightly** to cover all areas. IMPORTANT: When pressing the red button, keep machine moving so vibrating brush does not agitate in one place.
- **Liquid recovery.** You should recover 70 - 80% of the liquid used depending on your carpet type. With Berber carpet, you may recover a little less liquid.
- **Avoid excess foam** in the white UPPER tank which can be expelled through the machine and may affect your carpet. If foaming occurs, add 1/4 to 1/2 cup Rug Doctor Anti-Foam to white UPPER tank.
- **If you replace furniture before the carpet is completely dry,** place aluminum foil under furniture legs to prevent stains. Leave aluminum foil under furniture legs until carpet is completely dry.
- **For faster drying,** ventilate area. Open doors and windows. Place fans pointed downward on carpet. Turn on heat in damp or cold weather. Turn on air conditioner in humid or hot weather. This is highly recommended when cleaning Berber carpets.
- **Cleaning Berber carpet.** You can use your Rug Doctor machine to clean Berber carpet. For best results, make only one pass while depressing the thumb switch to release solution. Make a second pass over the same area without pressing the switch so that you are only vacuuming the liquid. Make sure the vacuum slot at the front bottom edge of the machine is snug against the carpet.

# Cleaning Carpets

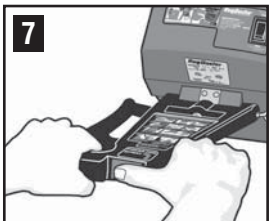
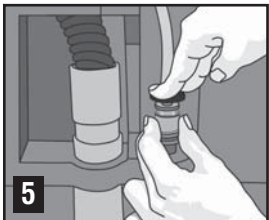

When cleaning an entire room, move furniture to the center of the room. Begin cleaning where furniture was, then return furniture to its original location. Avoid staining carpet by placing aluminum foil under furniture legs. Clean remainder of carpet. When finished, leave aluminum foil under furniture legs until carpet is completely dry. Complete the following steps to clean your carpets.

- Using a normal dry vacuum cleaner, sweep the area you want to clean to remove loose dirt before using the Rug Doctor machine. This helps keep the brushes and water vacuum system efficient.
- Pre-treat any special problem areas with the appropriate Rug Doctor solutions.
- Depending on how dirty carpets are, mix 1/4 to 1/2 cup of **Rug Doctor Carpet Cleaner** product per gallon of hot tap water in a clean bucket. Water should not be so hot as to scald or burn skin. The lower tank **C** capacity for the Rug Doctor Mighty Pro is 2.6 gallons and for the Rug Doctor Wide Track is 3.7 gallons. (ILLUS.1)
- Lower the retaining wire **A** and remove the white UPPER tank **B**.
- Fill the LOWER tank **C** with the cleaning solution you just mixed by pouring through the white filter screen. Machine is full when liquid halfway covers filter screen. (ILLUS.2)
- If using **Rug Doctor Anti-Foam**, add 1/4 to 1/2 cup to white UPPER tank **B** (ILLUS.3). Slip tank back in place and seal tank and clear dome **D** securely by replacing retaining wire **A** (ILLUS.4).
- Check the back of the machine to ensure hose connections are secure and set up to clean carpet instead of upholstery. (ILLUS. 5)
- Plug in the power cord and position the machine. Refer to label on top of the machine **E**. Press the "ON" switch for CARPET cleaning on the top of the machine (ILLUS.6).
- While depressing the red button on the handle **F** (ILLUS.7), pull the machine slowly and steadily backward in a straight line, keeping vacuum slot **G** against the carpet surface. You will begin to see soiled solution entering the clear dome **D**. (If you don't, stop and refer to the *Troubleshooting* section.)  
IMPORTANT: When depressing the handle button, keep machine moving so the vibrating brush does not agitate in one place. (ILLUS.8)
- Release the button 6 to 12 inches before ending each pass to stop cleaning solution. Tilt machine back and push it forward to position it for another backward cleaning pass (ILLUS.9). Continue cleaning in this manner, overlapping each pass slightly. When the lower tank runs out of cleaning solution, the pump sound will increase in volume slightly and dirty water will stop entering the dome. Switch the machine "OFF". Remove and empty the white UPPER tank **B** by pouring dirty solution into a toilet or outdoors (ILLUS.10). Rinse the upper tank and refill the LOWER tank **C** with clean solution/water mixture. If you are near the end of your cleaning job, fill the LOWER tank half full so it empties by the end of your job. Replace the upper tank **B**. Continue the cleaning process until area to be cleaned is covered.
- When cleaning is complete, switch the machine OFF. To drain and clean the machine, refer to the *Cleaning Your Machine* section.

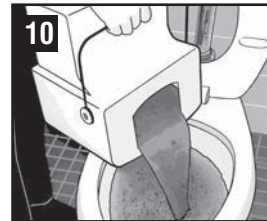
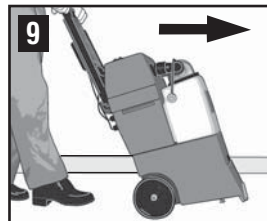
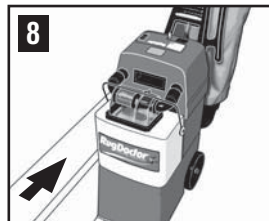
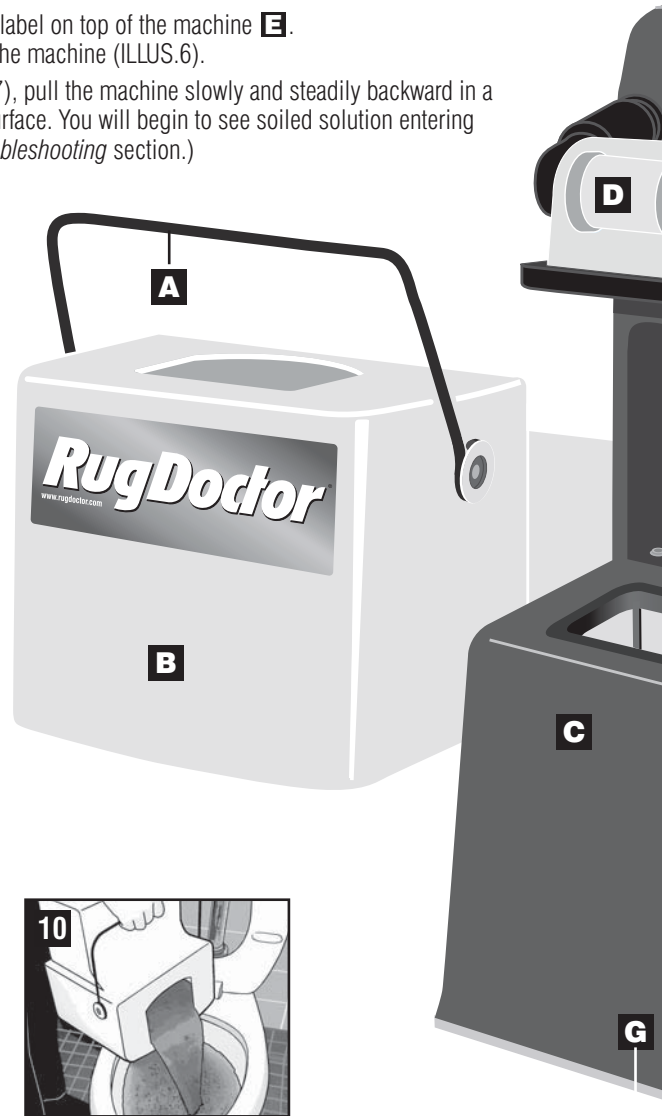

# Cleaning Upholstery

Always use Anti-Foam with Upholstery Cleaner or when needed to prevent excess sudsing in the upper (white) tank. If the Rug Doctor machine ingests foam through the dome filter, damage to the carpet and vacuum motor could result.

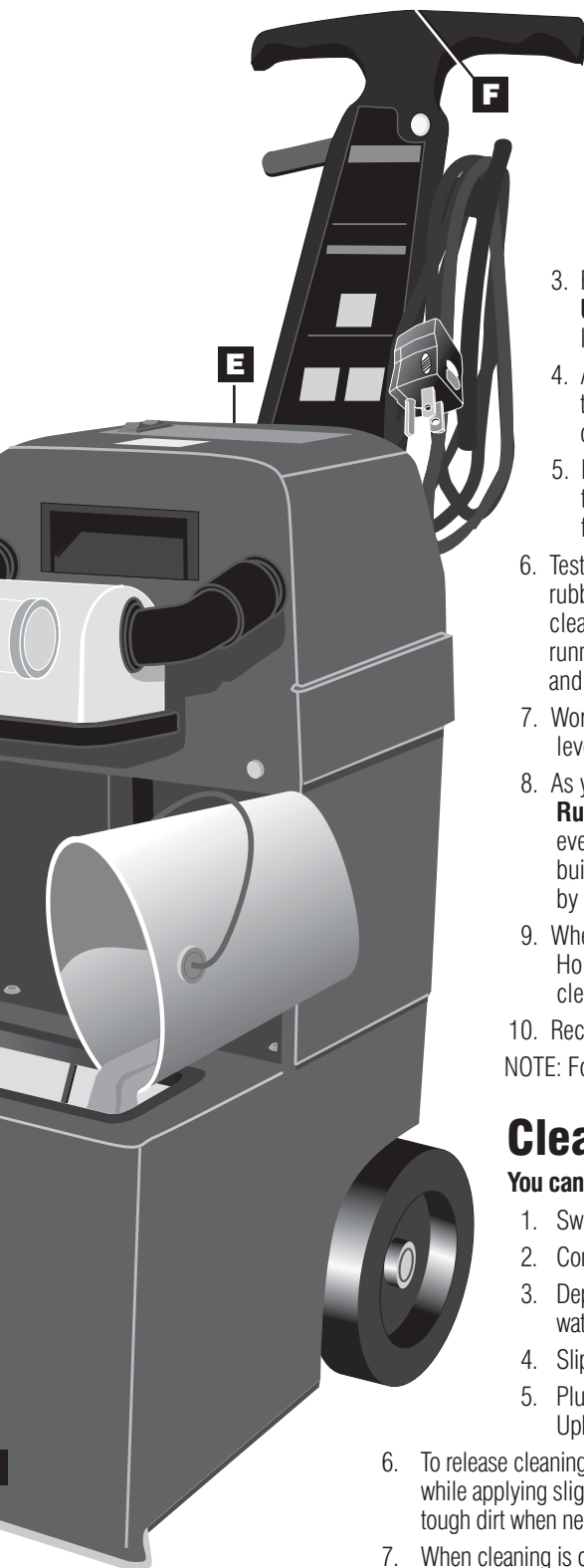

1. Prepare surfaces for cleaning by thoroughly vacuuming or brushing. When cleaning and drying cushions, first spread sheets or towels on the floor as a drying surface for the dampened cushions.
2. Disconnect the machine's large vacuum hose. Reconnect the top portion to the large vacuum hose of hand tool **H**. Slide down the brass "quick coupler" ring and pull out the small solution hose. Slide down the ring again to insert the metal end of the hand tool solution hose **I** (ILLUS. 11). Release the brass ring to secure. Tug gently on the hose to make certain the connection is secure.
3. Remove the white UPPER tank **B**, mix **Rug Doctor Upholstery Cleaner** in a clean bucket according to label directions and pour into LOWER tank **C**.
4. Add 1/4 to 1/2 cup of **Rug Doctor Anti-Foam** to white UPPER tank **B**. Slip the tank back in place and seal the tank and clear dome **D** securely by replacing the retaining wire **A**.
5. Plug in the power cord and position the machine. Refer to the label on top of the machine **E**. Turn on the machine by pressing the "ON" switch for UPHOLSTERY/ HAND TOOL cleaning on the top of the machine.
6. Test upholstery for colorfastness by first cleaning a small, hidden area, then rubbing the test area with a white paper towel. If no color appears, continue cleaning. A little color on the towel means there's some chance of color running, but it's likely you can still clean safely. Try using cool or cold water and test again with a white paper towel.
7. Working at a slow, steady pace, begin cleaning by squeezing the hand tool lever as you pull the tool over fabric (ILLUS.12). Overlap strokes slightly.
8. As you clean, with the vacuum on, squirt or vacuum a small amount of **Rug Doctor Anti-Foam** into the small (vacuum) opening of the hand tool every few minutes to minimize suds buildup in the vacuum hose. If foam builds up around the hand tool, pull slightly faster or vacuum excess solution by passing over area a second time without squeezing the lever on the hand tool.
9. When cleaning is complete, switch the machine OFF. Disconnect both of the hoses from the machine. Holding the hose ends over a sink, squeeze the hand tool trigger until all liquid is drained. To drain and clean the machine, refer to the *Cleaning Your Machine* section.
10. Reconnect the machine vacuum and solution hoses.

NOTE: For velvet upholstery, fluff up damp pile with a soft brush or towel to keep from matting.

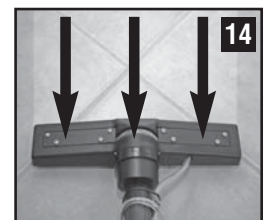
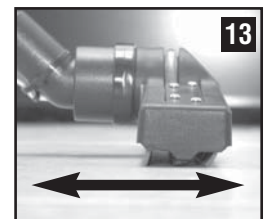
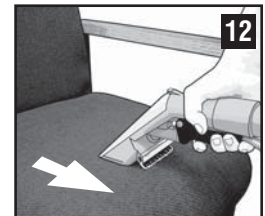
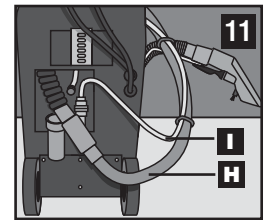

## Cleaning with Optional Floor Doctor Attachment

You can use **Rug Doctor Oxy-Steam Carpet Cleaner** to clean hard floors with exceptional results.

1. Sweep area to be cleaned if there is loose dirt and debris present.
2. Connect to rear of machine using 12' hose set as you would connect the Universal Hand Tool (ILLUS. 11).
3. Depending on how dirty floors are, mix 1/4 to 1/2 cup of **Rug Doctor Oxy-Steam** per gallon of hot tap water in a clean bucket (water should not be so hot as to burn skin) and fill LOWER tank of machine.
4. Slip the white tank back in place and seal the tank and clear dome securely by replacing the retaining wire.
5. Plug in the power cord and position the machine. Turn on the machine by pressing the ON switch for Upholstery/Hand Tool Cleaning on top of the machine.
6. To release cleaning solution, squeeze the trigger on the Floor Doctor handle. Move the Floor Doctor in a back and forth motion while applying slight pressure and keeping the tool head parallel to the floor (ILLUS. 13). The brush is designed to help remove tough dirt when necessary. For tile floors, move the Floor Doctor head at an angle to the grout line for best results (ILLUS. 14).
7. When cleaning is complete, switch the machine OFF. To drain and clean the machine, refer to the *Cleaning Your Machine* section. Drain the Floor Doctor/machine hose set after disconnecting it from the machine – to ensure that no excess liquid is left in the hose set, squeeze the trigger on the Floor Doctor.

# Maintaining Your Rug Doctor Machine

Follow these guidelines to ensure your Rug Doctor machine will last a lifetime. Failure to comply with the instructions, cautions and safety warnings in this manual voids the warranty

## Cleaning Your Machine

- Drain the machine by spraying out remaining solution over a floor drain or outdoors (never in rain or on wet ground). Do not allow machine to stand in liquid while emptying. For best results, spray out liquid with machine set to Upholstery Hand Tool to prevent brushes from movement and wear while emptying. Using this method you can spray out remaining liquid either through Hand Tool or machine spray tips.
- Clean the vibrating brush. After each use, unplug the machine from power source and use your finger or an old comb to remove any debris from the vibrating brush. If you used any Rug Doctor attachments, also remove debris from the attachment vacuum slot.
- Clean the vacuum filter. After each use, inspect the cylindrical filter screen located inside of the clear plastic dome on the front of the machine. If debris is present, remove the filter screen by pushing it right and compressing the spring until the filter end is clear of the dome. Clean by running water through the screen from the inside to the outside. Replace by compressing the spring wire and inserting the black end securely into place in the hole inside the dome.
- Clean the solution tank filter screen. After each use, inspect the rectangular filter screen located in the fill opening of the solution (lower) tank. If debris is present, remove screws that hold the filter in place and remove filter from the solution tank opening. Clean filter by holding it under a water faucet and letting the water run through the filter in the opposite direction from the normal filling flow. Replace the filter screen and fasten it in place with the two mounting screws.
- Clean the solution tank line strainer. When the solution tank filter screen is removed for cleaning, inspect the cylindrical filter mounted on the end of the solution line inside of the tank. The Wide Track has two cylindrical filters. If debris is present, remove the filter by pulling it off the solution line. Hold the filter under flowing water until debris is cleared. Replace the filter by pushing it over the end of the solution hose.
- Remove carpet fibers from vacuum slot. Periodically check the vacuum slot on the bottom front of the machine for debris. Remove any fiber, hair or other debris that may be caught in the slot using a stiff wire with a hook on the end. You can use wire coat hanger. Always make sure the machine is in the "OFF" position, unplugged and the tanks are empty.

## Caring for Your Machine

- Always use recommended cleaning agents. Do not use dye or bleach in this machine.
- Oil the machine. Periodically use a light lubricating oil to deter corrosion of quick-disconnect and other moving parts. Be sure to wipe all excess oil from lubricated areas.
- Store the machine indoors out of dusty, wet and freezing areas. This prolongs the life of your Rug Doctor machine and helps keep it trouble free.
- Do not expose Rug Doctor machines to freezing temperatures for a prolonged period of time. In freezing temperatures, liquid in the machine system can damage the pump and solution hoses. If you must expose the machine to temperatures at or below 32 °F (0 °C), take precautions to protect the pump and solution hoses.
- Use care when transporting your Rug Doctor machine. Rug Doctor machines are designed for rugged use. However, avoid mishandling such as dropping the unit or transporting it in an open van or truck. Jarring from sudden vehicle starts or stops can damage the machine.

## Obtaining Service for Your Machine

- Register your new carpet cleaner by completing and returning the attached Rug Doctor Product Registration Card. The registration entitles you to service work and replacement parts during the warranty period should your cleaner need repairs.
- Do not attempt repair on a machine under warranty. Servicing and warranty repairs should be performed by an authorized service representative only.
- If you experience an operational problem, call our Consumer Support Hotline at 1-800 RUG DOCTOR (1-800-784-3628). Basic replacement parts can be ordered through Consumer Support. If repair is required, you will be directed to take or ship your unit to the nearest authorized repair station. Rug Doctor recommends you keep the original carton and packing materials.
- Rug Doctor will, without charge, during the Warranty Period, repair or replace, at its option, any component part which is defective or that malfunctions when the machine is returned within the warranty period.
- When returning a machine for non-warranty or out of warranty repairs, always insure the carpet cleaner for its full value before shipping.
- The warranty entitles the owner of a Rug Doctor machine to specific legal rights. You also may have other rights. Rights vary state to state.
- Rug Doctor's liability is limited to the cost of the unit. Some states do not allow the exclusion or limitation of incidental or consequential damages, so this limitation or exclusion may not apply to you. If you have questions about your warranty, please call Rug Doctor at 1-800 RUG DOCTOR.



## Available Replacement Parts for Your Machine

Refer to the following diagram if you need to order basic replacement parts for your machine. Do not use replacement parts other than those available through Rug Doctor. Do not attempt repairs on a machine under warranty.

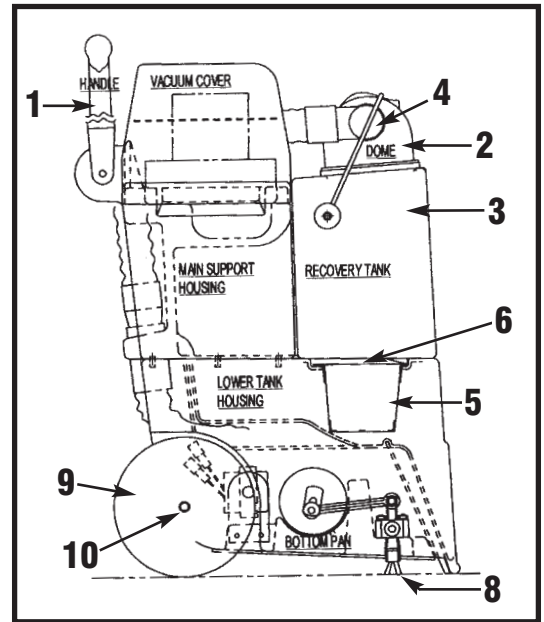

1. 92735 Handle Assembly
2. 92030 Dome Assembly
3. 92359D Mighty Pro Recovery Bucket Assembly  
92532D Wide Track Recovery Bucket Assembly
4. 10460 Dome Filter
5. 60400 Lower Tank Fill Filter
6. 20091 Screw, #8 X 1/2" (for lower tank Fill Filter)
7. 10461 Lower Tank Sump Filter (not shown)
8. 60719 Mighty Pro Brush Strip  
60723 Wide Track Brush Strip
9. 10281 Mighty Pro Wheel  
10231 Wide Track Wheel
10. 11183 Wheel Hub Cap

## Replacing a Brush

1. Remove the old brush strip from the machine.
2. Align the holes on the new brush strip with the fastening arm holes on the machine.
3. Place a straight edge across the bottom of the wheel and the stainless steel front. Adjust the brush height so that it lightly touches the straight edge. If the brush extends below the straight edge the machine may bounce when you use it next.
4. Use the screws and nuts from the previous brush to securely attach the new brush strip. Make sure the nuts attach on the brush side that is closest to the front of the machine.

## Troubleshooting

Use this section to help resolve any issues you experience with your machine. If you do not find the answer to your questions here, please contact the Rug Doctor hotline at 1-800 RUG DOCTOR (1-800-784-3628) or through the Rug Doctor web site at [RugDoctor.com](http://RugDoctor.com). The Rug Doctor hotline is available 7 days a week (except on legal holidays) from 8 am to 8 pm (CST).

### Power Issues

Always use a grounded outlet with this machine. Not doing so can result in electrical shock. Refer to the *Grounding Instructions* section for more information.

#### The machine switch is on, but there is no power.

Try the following steps to resolve this issue:

- Make sure the electrical cord is plugged in. If the electrical outlet is connected to a wall switch, make sure the wall switch is in the ON position.
- Check the circuit breaker switch on the machine and reset if necessary.
- Check the ALCI plug and reset if necessary.
- Check the wall circuit breaker. If it is off or if a fuse is blown, unplug the machine and reset the circuit breaker or replace the fuse. Plug the machine into a different wall plug before beginning again.
- Check the power cord. If it is defective, please contact the manufacturer or an authorized service agent. An authorized professional must repair the machine.

#### The machine switch is on, but there is intermittent power.

Please contact the manufacturer or an authorized service agent. Faulty electrical cable, defective switches, or loose terminal connections can cause intermittence. An authorized professional must repair the machine.

## Vacuum Issues

### **There is little or no vacuum at the hand tool or machine vacuum slot.**

Try the following steps to resolve this issue:

- Make sure the dome is securely sealed with the retaining wire to the top of the recovery tank.
- Check the hose connection at the back of the machine and secure if necessary.
- Clean the filter that is in the dome.
- Remove any accumulated debris around the vacuum slot.

If none of the above steps fix the problem, the vacuum hose assembly inside the machine may be defective. Contact the manufacturer or an authorized service agent. An authorized professional must repair the machine.

### **The machine is on, but the vacuum motor works intermittently.**

Please contact the manufacturer or an authorized service agent. A loose wiring connection can cause intermittence. An authorized professional must repair the machine.

## Solution System Issues

### **The machine lost water pressure.**

Check the level of solution in the lower tank and refill if necessary.

### **The machine is on and the spray button or hand tool lever is depressed, but no spray comes out.**

Try the following steps to resolve this issue:

- Make sure the ON switch is set to the appropriate setting.
- Check the small solution line hose at the back of the machine. Connect the line securely at the quick coupler if necessary.
- Brush the spray tips with a soft-bristle brush, such as an old toothbrush, to remove any build-up that may be clogging the tips. Do not brush spray tips with any kind of wire or metal brush. Do not try to unclog the tip by poking it with a pin or any other object.
- **Hand Tool only:** Remove the spray tip with a nut driver. Rinse the tip and blow air through it to remove any build-up that may be clogging the tip. Reattach the tip with the nut driver. Make sure to position the tip opening so that it sprays side to side.
- Check the lower tank sump filter inside the lower tank and clean if necessary. Refer to the *Maintaining Your Rug Doctor Machine* section in this document for more information.

### **The spray from the spray tip(s) is weak or uneven.**

- Brush the spray tips with a soft-bristle brush, such as an old toothbrush, to remove any build-up that may be clogging the tip. Do not brush spray tips with any kind of wire or metal brush. Do not try to unclog the tip by poking it with a pin or any other object.
- **Hand Tool only:** Remove the spray tip with a nut driver. Rinse the tip and blow air through it to remove any build-up that may be clogging the tip. Reattach the tip with the nut driver. Make sure to position the tip opening so that it sprays side to side.
- Check the lower tank sump filter inside the lower tank and clean if necessary. Refer to the *Maintaining Your Rug Doctor Machine* section in this document for more information.

## Excessive Foaming

Foam in the recovery tank is caused most often by Upholstery Cleaner solution or by cleaning carpets where spray foams have been used previously. Add 1/4 to 1/2 cup of Anti-Foam to the white upper tank. If you are cleaning upholstery, in addition to adding Anti-Foam to the upper tank, add small amounts of Anti-Foam at the hand tool vacuum slot periodically while cleaning.

## Carpet Discoloration

### **Stained areas appear on the carpet after cleaning.**

Stained areas can appear after cleaning due to old, deep spills “wicking up” to the surface of the carpet as the carpet dries.

Try the following steps to resolve this issue:

- After the carpet is completely dry, spray a light application of Rug Doctor Urine Eliminator directly on affected areas following the product label instructions.
- After the carpet is completely dry, clean the area with your Rug Doctor machine making sure to avoid overwetting the carpet. Stains may continue to appear if the carpet is overwetted.

### **Streaks appear on the carpet during cleaning.**

- Brush the spray tips with a soft-bristle brush, such as an old toothbrush, to remove any build-up that may be clogging the tip. Do not brush spray tips with any kind of wire or metal brush. Do not try to unclog the tip by poking it with a pin or any other object.
- Check the brush bristles for damage or wear. Replace the brush if necessary.

You can register your Rug Doctor machine at [www.rugdoctor.com](http://www.rugdoctor.com)

# FIVE YEAR CONSUMER LIMITED WARRANTY:

**Rug Doctor**<sup>®</sup>  
The Carpet Care Experts



**Mighty Pro**<sup>®</sup> / **WIDETRACK**<sup>™</sup>

**FIVE (5) YEAR LIMITED CONSUMER WARRANTY** Rug Doctor gives you, the original purchaser, who retains proof of purchase from Rug Doctor or an authorized Rug Doctor Dealer, this limited warranty ("warranty") for your MIGHTY PRO<sup>®</sup> or Wide Track<sup>™</sup> carpet cleaning machine acquired for normal household use (commercial or rental use is excluded). You are responsible to notify Rug Doctor within thirty (30) days of original purchase if any parts or components are missing on your MIGHTY PRO<sup>®</sup> machine.

**WHAT DOES THIS WARRANTY COVER / HOW LONG DOES THE WARRANTY LAST:** Rug Doctor will, for the original purchaser, repair or replace including labor, any part that is defective in material or workmanship within five (5) years of purchase date; ten (10) years on outer housing parts. This warranty applies for normal household use only.

**WHAT THE WARRANTY DOES NOT COVER:** The following exclusions apply for part(s) failures due to: 1) normal wear and tear; 2) machine alterations and 3) abuse or misuse of the machine, including use not in accordance with this "Instruction Guide". This warranty does not provide for a refund of the purchase price. For best operating efficiency and cleaning use of Rug Doctor products is recommended.

Use of the machine for rental voids the warranty and is not permitted under Federal Law (see "UNAUTHORIZED USE" statement below). Commercial use is excluded under this warranty however the "ONE YEAR LIMITED COMMERCIAL WARRANTY" applies, as shown below.

Rug Doctor is not liable for any consequential or incidental damages of any nature involving the purchase/use of your carpet cleaning machine. Rug Doctor's liability will not exceed the purchase price of the machine.

**Some states do not allow the exclusion or limitation of incidental or consequential damages, so the above limitations or exclusions may not apply to you.**

**EXPENSES:** If a machine is returned to a warranty center for repair within thirty (30) days of original purchase, Rug Doctor pays the freight charges both to a warranty center and back to you. Thereafter, you may be directed to take the machine to a local repair center or required to ship the machine to a Rug Doctor warranty center should additional repairs be required during the warranty period. You will be responsible to pay any freight charges for shipment to the warranty center for repairs occurring after the initial thirty (30) days. Rug Doctor will pay the freight charges back to you.

**HOW STATE LAWS APPLY:** This warranty gives you specific legal rights. You may also have other rights which vary from state to state.

**HOW DO I GET SERVICE UNDER THIS WARRANTY?** TO OBTAIN WARRANTY ASSISTANCE, please call 1-800 RUG DOCTOR (1-800-784-3628) (8 am to 8 pm Monday - Sunday CST) or e-mail [consumer.support@rugdoctor.com](mailto:consumer.support@rugdoctor.com). Rug Doctor will need the following information in order to assist you: your name, address and telephone number, product model and serial number, proof of purchase showing date and place of purchase. Please explain the nature of the problem.

Rug Doctor will review all the facts involved and advise you as to recommended procedure. We recommend you keep the original carton and packing materials.

Rug Doctor, Inc.  
4701 Old Shepard Place  
Plano, Texas 75093

Web Site: [www.rugdoctor.com](http://www.rugdoctor.com)  
E-mail: [consumer.support@rugdoctor.com](mailto:consumer.support@rugdoctor.com)

**UNAUTHORIZED USE:** Use of this carpet cleaning machine with Rug Doctor trademarks for rental purposes is UNAUTHORIZED and is in violation of U.S.C. Section 1114(l) and 15 U.S.C. Section 1125(a).

## ONE (1) YEAR LIMITED COMMERCIAL WARRANTY

All of the warranty terms as expressed above shall apply in all respects, for the original United States purchaser of a MIGHTY PRO<sup>®</sup> carpet cleaning machine, who purchases/uses the machine commercially (not in household use), except that the limited warranty period for the defects in material or workmanship as well as housing parts shall be one (1) year.

## Now that you have the power of the professionals, make sure you keep cleaning like one

■ **Rug Doctor Oxy-Steam™ Carpet Cleaner** has oxygen cleaning boosters that lift out embedded dirt, allergens and bacteria from deep within carpets. While it cleans better and deeper, Oxy-Steam is actually very gentle on carpets and is safe to use even on wool and wool-blend carpets.

■ **Rug Doctor SpotBlok® Carpet Cleaner** cleans, beautifies, and deodorizes carpets while adding stain protection every time you clean. Rug Doctor Carpet Cleaners leave no sticky residues that can cause carpets to quickly re-soil.

■ **Rug Doctor Hi-Traffic Pre-Treatment** improves carpet cleaning results by lifting stubborn, oily soils found in high-traffic areas. The trigger sprayer makes it easy to apply.

■ **Rug Doctor Urine Eliminator** is specially formulated to remove odors and associated stains from urine, vomit, feces, blood, perspiration, and other pet- and human-origin stains. Urine Eliminator has active enzymes that eliminate the source of the stain and odor.

■ **Rug Doctor Spot & Stain Remover** removes stains from coffee, juice, sauces, chocolate syrup, permanent marker, makeup, oil, mud, grass and more. It solves nearly every kind of common spill or stain.

■ **Rug Doctor Odor Remover** with advanced bio-enzyme technology eliminates the source of foul odors resulting from food, smoke, mildew, animal waste and other odors trapped in carpeting. It can be used as a pre-treatment, a stand alone product or as an additive to the cleaning solution.

■ **Rug Doctor Upholstery Cleaner** cleans and brightens upholstery without harming delicate fabrics or upholstery backing. Upholstery cleaner keeps furniture, car interiors, RVs – anything with upholstery – looking like new.

■ **Rug Doctor Anti-Foam** is used in the machine's recovery tank. It eliminates suction loss caused by foam that can develop as dirty water enters the recovery tank.



## Rug Doctor®

**Rug Doctor, Inc.**

4701 Old Shepard Place, Plano, TX 75093-9065

1-800 RUG DOCTOR (1-800-784-3628)

[RugDoctor.com](http://RugDoctor.com)

# Rug Doctor®

**IMPORTANT! Please fill out and return within the next 10 days.**

Proper registration will serve as proof of purchase in the event your original receipt is misplaced or lost or in the event of theft or loss of your machine. It will also help to expedite processing of any warranty claims. By answering the additional questions, you will help us to better understand our customers and their cleaning needs for future product development. We appreciate your help in providing these answers. We consider your information confidential and will not allow its use by any company other than Rug Doctor. Thank you!

SERIAL NO. (See Machine Data Plate)  
 DO NOT LEAVE BLANK

**Your warranty registration is important. Please send it in within 10 days!**

**IMPORTANT! Please fill out and return within the next 10 days.**  
 Proper registration will serve as proof of purchase in the event your original receipt is misplaced or lost and may expedite the processing of any warranty claim. It also will serve as proof of purchase in the event of theft or loss. The additional questions will help us to develop products to meet your cleaning needs in the years to come. We appreciate your help in providing this information. We consider your information confidential and will not allow its use by any company other than Rug Doctor. Thank you for choosing Rug Doctor!

1.  Mr.  Mrs.  Ms.  Miss **PLEASE PRINT**

FIRST NAME \_\_\_\_\_ M.I. \_\_\_\_\_ LAST NAME \_\_\_\_\_

STREET ADDRESS \_\_\_\_\_

MAILING ADDRESS (IF DIFFERENT) \_\_\_\_\_

CITY \_\_\_\_\_ STATE/PROVINCE \_\_\_\_\_ ZIP \_\_\_\_\_

PHONE NUMBER: \_\_\_\_\_ E-MAIL ADDRESS: \_\_\_\_\_

2. Date of purchase: \_\_\_\_\_

3. Where did you purchase this product?  
 a.  From manufacturer - f.  Catalog Showroom  
 b.  Retail and called. g.  Membership Club  
 c.  From internet h.  TV/Appliance Store  
 d.  Received as a gift i.  Vacuum Specialty Store  
 e.  Discount Dept. Store j.  Hardware Store  
 k.  Military PX  
 l.  Other \_\_\_\_\_

4. Store Name \_\_\_\_\_

5. Do you intend to use your new Rug Doctor machine primarily for cleaning carpets/upholstery in:  
 a.  Your home b.  Your business

6. How did you first become aware of this Rug Doctor Product? (Please check only one.)  
 a.  TV Advertisement e.  Magazine Advertisement  
 b.  Internet f.  Consumer Magazine Article  
 c.  Friend/Relative's g.  Store Display/Demonstration  
 Recommendation h.  Salesperson's Recommendation  
 d.  Newspaper Advertisement i.  Other \_\_\_\_\_

7. Did you see the Rug Doctor Informercial on TV?  Yes  No

8. Did you visit the Rug Doctor website (www.rugdoctor.com) before making your purchase decision?  Yes  No

9. Which factors most influenced you to purchase this Rug Doctor product: (Please check up to 3 boxes.)  
 a.  Rug Doctor's reputation g.  Warranty  
 b.  Prior experience with Rug Doctor h.  Quality/Durability  
 c.  Style/Appearance i.  Friend/Relative's recommendation  
 d.  Value for the price j.  Ease of operation  
 e.  Product package k.  Salesperson's recommendation  
 f.  Special attachments l.  Other \_\_\_\_\_

10. Which other brands did you seriously consider before buying a Rug Doctor machine?  
 a.  Bissell d.  Regina  
 b.  Hoover e.  Other commercial models  
 c.  Eureka f.  Other \_\_\_\_\_

11. Who made the decision to purchase the Rug Doctor brand machine over another brand?  
 a.  Yourself b.  Spouse c.  Joint decision

12. Marital Status:  
 a.  Married c.  Divorced/Separated  
 b.  Widowed d.  Never Married (Single)

13. Year of Birth (of person whose name appears above): \_\_\_\_\_

14. Excluding yourself, what is the SEX and AGE (in years) of children and other adults living in your household?  
 a.  No one else in household  
 Age \_\_\_\_\_ Male  Female  Male  Female  
 Age \_\_\_\_\_ Male  Female  Male  Female  
 Age \_\_\_\_\_ Male  Female  Male  Female

15. Occupations of household decision makers:  
 a.  Homemaker  You  Spouse  
 b.  Self Employed/Business Owner  You  Spouse  
 c.  Clerical or Service Worker  You  Spouse  
 d.  Tradesman/Machine Operator/Laborer  You  Spouse  
 e.  Professional/Technical  You  Spouse  
 f.  Sales/Marketing  You  Spouse  
 g.  Middle Management  You  Spouse  
 h.  Upper Management/Executive  You  Spouse  
 i.  Student  You  Spouse  
 j.  Retired  You  Spouse

16. Which group describes your annual family income?  
 a.  Under \$15,000 g.  \$40,000-\$44,999  
 b.  \$15,000-\$19,999 h.  \$45,000-\$49,999  
 c.  \$20,000-\$24,999 i.  \$50,000-\$59,999  
 d.  \$25,000-\$29,999 j.  \$60,000-\$74,999  
 e.  \$30,000-\$34,999 k.  \$75,000-\$99,999  
 f.  \$35,000-\$39,999 l.  \$100,000 and over

17. Education: (Please check all that apply)  
 a.  Some High School or less  You  Spouse  
 b.  High School or GED  You  Spouse  
 c.  Vocational/Technical School  You  Spouse  
 d.  2 Year College Degree  You  Spouse  
 e.  4 Year College Bachelor's Degree Program  You  Spouse  
 f.  Additional Graduate School  You  Spouse

18. For your primary residence, do you:  
 a.  Own a house? c.  Rent a house?  
 b.  Own a townhouse or condominium? d.  Rent an apartment, townhouse or condominium?

Please continue on back

**IMPORTANT! Please fill out and return within the next 10 days.**

Proper registration will serve as proof of purchase in the event your original receipt is misplaced or lost and may expedite the processing of any warranty claim. It also will serve as proof of purchase in the event of theft or loss. The additional questions will help us to develop products to meet your cleaning needs in the years to come. We appreciate your help in providing this information. We consider your information confidential and will not allow its use by any company other than Rug Doctor. Thank you for choosing Rug Doctor!

**Your warranty registration is important. Please send it in within 10 days!**

Place Stamp Here

**Rug Doctor, L.P.**  
 Consumer Support Department  
 4701 Old Shepard Place  
 Plano, TX 75093-9065

\_\_\_\_\_  
 \_\_\_\_\_  
 \_\_\_\_\_

19. To help us understand our customers' lifestyles, please indicate the interests and activities that you and your spouse enjoy on a regular basis:

- 1.  Recycling
- 2.  Golf
- 3.  Physical fitness/exercise
- 4.  Running/jogging
- 5.  Snow skiing frequently
- 6.  Tennis frequently
- 7.  Camping/hiking
- 8.  Fishing frequently
- 9.  Hunting/shooting
- 10.  Power boating
- 11.  Sailing
- 12.  Walking for health
- 13.  Self improvement
- 14.  Health/natural foods
- 15.  Vegetable gardening
- 16.  Flower gardening
- 17.  Houseplants
- 18.  Home workshop/do it yourself
- 19.  Needlework/knitting
- 20.  Sewing
- 21.  Crafts
- 22.  Automobile work
- 23.  Electronics work
- 24.  Photography
- 25.  Coin/stamp collecting
- 26.  Stereo, recorded music
- 27.  Watching videos
- 28.  Watching sports on TV
- 29.  Watching televised game shows
- 30.  Internet surfing
- 31.  Avid book reading
- 32.  Bible/devotional reading
- 33.  Real estate investments
- 34.  Stock/bond investments
- 35.  Entering sweepstakes
- 36.  Casino gambling
- 37.  Foreign travel
- 38.  Travel in the USA
- 39.  Recreational vehicle travel
- 40.  Attending cultural events
- 41.  Fine art/antiques
- 42.  Fashion clothing
- 43.  Gourmet cooking
- 44.  Wines
- 45.  Home furnishing/decorating
- 46.  Grandchildren
- 47.  Wildlife/environmental issues
- 48.  Other

20. Using the numbers in the above list, please indicate the 3 most important activities for:

You \_\_\_\_\_ Your Spouse \_\_\_\_\_

21. Please check all that apply to your household

- a.  Purchase items via internet
- b.  Purchase groceries via internet
- c.  Purchase items via catalog/mail order
- d.  Have a computer at home
- e.  Subscribe to cable TV
- f.  Subscribe to a satellite service
- g.  Have a dog
- h.  Have a cat
- i.  Support health charities
- j.  Member of frequent flyer program

22. What is your favorite magazine/periodical your spouse's \_\_\_\_\_

23. Do you have any ideas for products that would make carpet cleaning easier for you? \_\_\_\_\_

Thank you for taking the time to fill out this questionnaire. Your answers are greatly appreciated and will be kept in complete confidence.

If you have any comments about our product or additional suggestions, please write to us at: Rug Doctor

Consumer Support Department  
 4701 Old Shepard Place  
 Plano, TX 75093

You can e-mail us at consumer.support@rugdoctor.com or call 1-800 RUG DOCTOR.